

01

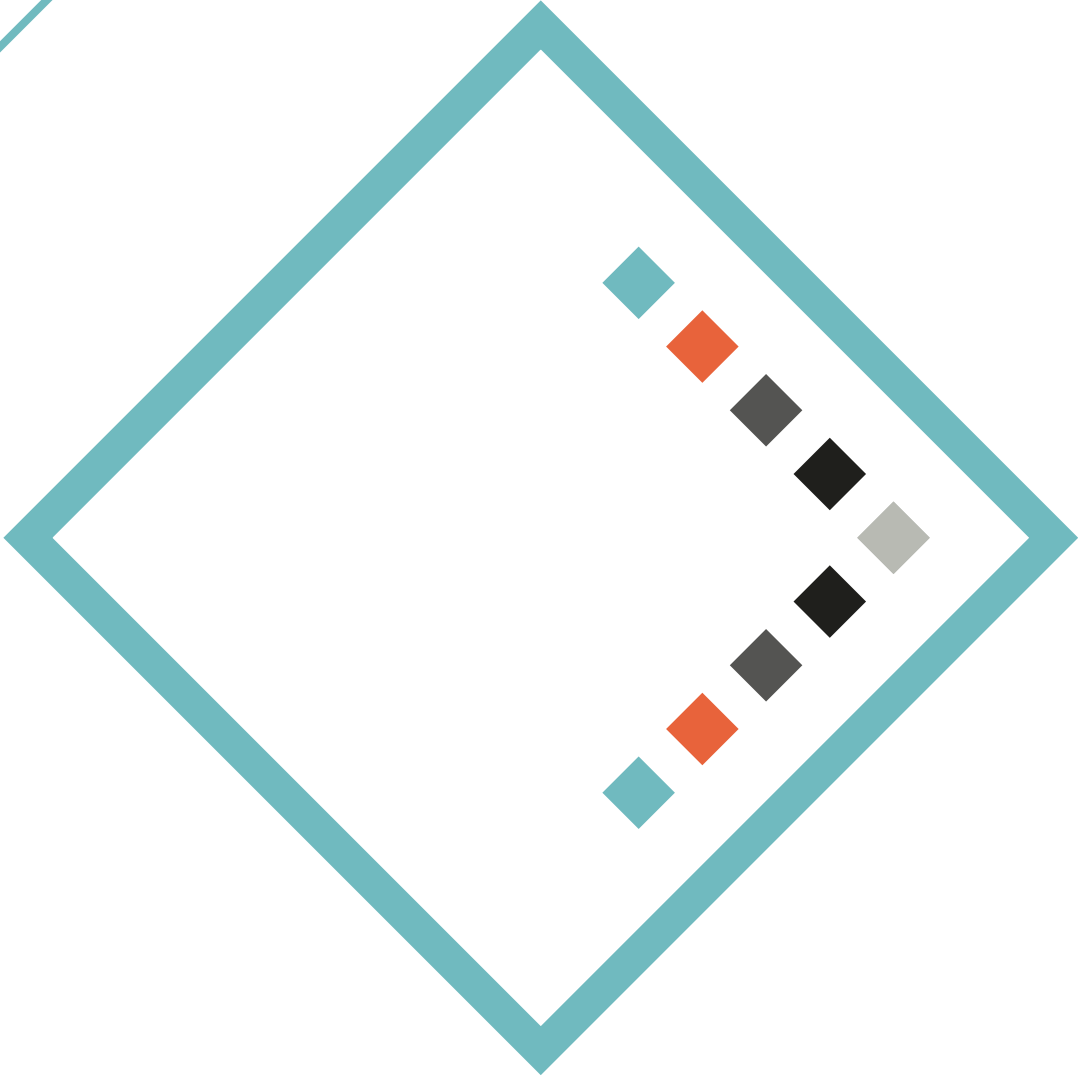
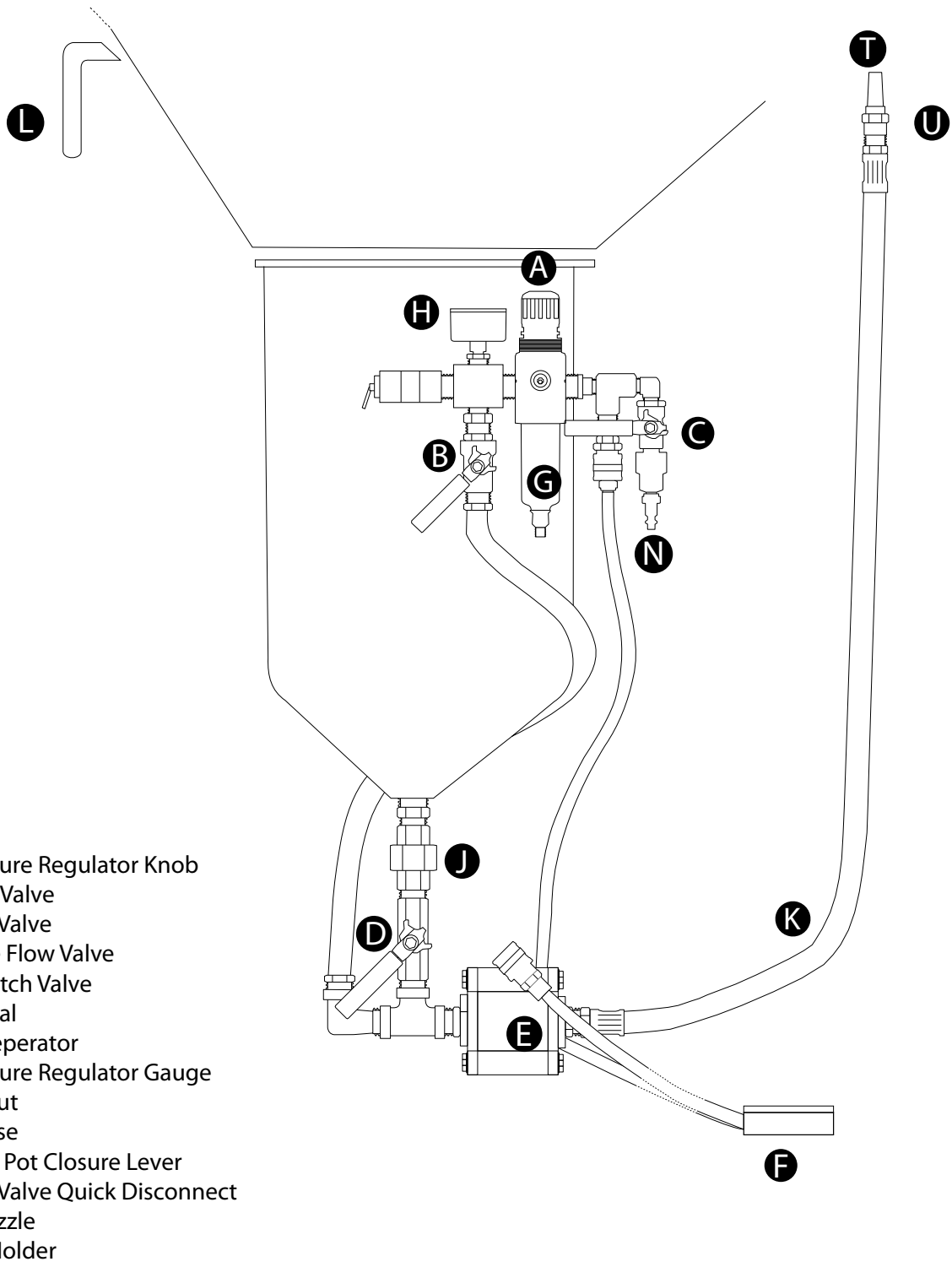

TABLE OF CONTENTS

Section 1 - Safety Information	1
Section 2 - Setup Guide	2
Section 3 - Operation Manual	3
Section 4 - Maintenance Manual	4

REFERENCE TABLE



- Ⓐ Air Pressure Regulator Knob
- Ⓑ Air Flow Valve
- Ⓒ Air Inlet Valve
- Ⓓ Abrasive Flow Valve
- Ⓔ Foot Switch Valve
- Ⓕ Footpedal
- Ⓖ Water Separator
- Ⓗ Air Pressure Regulator Gauge
- Ⓙ Union Nut
- Ⓚ Blast Hose
- Ⓛ Pressure Pot Closure Lever
- Ⓝ Air Inlet Valve Quick Disconnect
- Ⓣ Blast Nozzle
- Ⓤ Nozzle Holder

SAFETY INFORMATION

! WARNING

DO NOT attempt to operate this equipment until you have read and understand the potential hazards associated with operating this equipment and are able to follow all safety and operating procedures found in this manual.

Potential hazardous situations are identified whenever you see the following alert:

1.0 Potential Hazards

This is a summary of primary hazards, read the entire manual to understand all the potential hazards. This equipment is designed for etching glass with aluminum oxide abrasive media. NEVER use silica sand or abrasive containing silica with this equipment. Breathing dust from silica sand may cause silicosis, a fatal lung disease.

1.1 Electrical

1.1.1 Injury or death caused by electrical shock or fires caused by electrical shorts can occur if electrical outlets are not properly grounded and do not have the proper circuit breaker protection of 15 amps. Make sure the electrical outlet is grounded and is connected to a properly working 15 amp circuit breaker. DO NOT use extension cords to connect this equipment.

1.1.2 Always unplug power when doing repairs, maintenance or replacing lamp.

1.2 Lighting

1.2.1 The Lighting fixture inside the cabinet is an LED bulb. When replacing bulb do not exceed 100 watt.

1.2.2 The Lighting fixture inside the cabinet have seals to help keep dust out but are not explosion proof. Do not blast materials that may produce combustible dusts. Never use flammable solvents inside the cabinet.

1.3 Dusts

1.3.1 Prolonged breathing of dusts produced by blasting media and materials removed by blasting may result in serious respiratory injury or death. Health risks may vary with type of abrasive media and materials that are removed by blasting. NEVER use this equipment to blast materials that may produce toxic dusts such as lead. ALWAYS wear NIOSH approved respirators for ANY activity where you may be in contact with airborne dusts.

1.3.2 Abrasive media and dusts may cause irritation to the skin. Wear rubber or latex gloves when blasting and whenever the abrasive may come in contact with your skin.

1.3.3 Abrasive media and dusts may cause irritation to your eyes. Protective eye goggles and a dust mask should be worn whenever handling the abrasive, changing the abrasive and or servicing the dust collector.

1.3.4 ALWAYS shut off main air supply "lever C" at the end of each day. If the valve is left on and the air compressor supply shuts off at night the pot will ALWAYS shut.

depressurize and automatically open. When the air compressor comes back on the next day, air will run through the pot and abrasive and dust will blow out through the arm holes of the cabinet creating a hazardous condition of dust in the air.

1.4 Abrasive Blasting Medias

1.4.1 NEVER use silica sand or abrasive containing silica with this equipment.

Breathing dust from silica sand may cause silicosis, a fatal lung disease. We recommend and supply with your cabinet, 150 grit Brown Aluminum Oxide. Aluminum Oxide or Silicon Carbide are the recommended abrasives to use. Protective wear are recommended whenever handling the abrasive, cleaning the cabinet and or servicing the dust collector.

1.5 Blasting

1.5.1 The dust collector should be attached and operating whenever your sandcarving cabinet is in use. The cabinet door must be closed during blasting operation.

1.6 Pressure Pot

1.6.1 Failure to follow the procedures in this manual could result in serious injury or death from the sudden release of compressed air. NEVER attempt to open the pressure pot closure mechanism using the Pressure Pot Closure Lever (L). This could cause a sudden UNSAFE release of compressed air. The pressure pot opens automatically when the pot is depressurized. NEVER do maintenance on any component of the pressure pot while

the pot is pressurized. NEVER apply more than 100psi of incoming air pressure from the air compressor to the system. Set incoming air pressure from air compressor to 90psi. Set blasting pressure regulator on the pot to desired blasting pressure, normally between 25 psi - 35 psi.

The regulator is equipped with a safety valve. The safety valve will release if blasting pressure exceeds 100PSI.

SET UP

! WARNING

DO NOT attempt to operate this equipment until you have read and understand the potential hazards associated with operating this equipment and are able to follow all safety and operating procedures found in this manual.

Potential hazardous situations are identified whenever you see the following alert:

2.0 Set-Up Introduction

2.1 Requirements for Set-up

2.1.1 Tools Needed:

- 3/8" socket wrench or crescent wrench.
- Box knife

2.1.2 Electrical Requirements: (Grounded) 110-120 Volt 60 Hz 15 AMP circuit breaker

2.1.3 Compressed Air Requirements: Minimum Required CFM (Cubic Feet per Minute) 5.5 – 6.0 CFM Average blasting pressure @ 35psi = 5.46 CFM

2.2 Delivery & Unpacking Instructions

! WARNING

This equipment can weigh in excess of 300 lbs. To avoid injury, use proper lifting and moving equipment.

This equipment is shipped on a pallet and should be removed from the truck with a forklift or with the use of a lift gate.

2.2.1 Before removing the equipment from the shipping pallet remove the outer packing.

2.2.2 Remove all the contents inside the cabinet.

2.3 Cabinet Inspection

2.3.1 Before removing the equipment from

the shipping pallet inspect the cabinet for the following:

1. External damage to the cabinet, viewing glass, power connections, handles, and the pressure pot.
2. Check light fixture inside the cabinet to make sure it is tight and has not vibrated loose in shipping.

! NOTICE

If there are any external or internal damages to the equipment it must be noted on the carrier's bill of lading. Contact Rayzist customer service at 1-800-729-9478 immediately to process a damage claim. Keep the packaging intact. Take photos of damage. Receiver accepts all responsibility once the bill of lading is signed.

2.4 Parts Inventory

2.4.1 Make sure you have received all the following items with your cabinet.

- Mask Making Kit (if purchased with the cabinet).
- 50 lb 150 grit Aluminum Oxide
- HD Blast Hose with 3/32" Nozzle and holder (K).
- Abrasive Recovery Bucket (2 gallon plastic bucket)
- Foot Pedal Assembly with hoses.
- Sample Stencils

2.5 Removal from Pallet.

! WARNING

Removal of the cabinet from the pallet requires at least two people.

2.5.1 The cabinet is bolted to the 4x4 blocks mounted on the pallet. Locate the bolts and remove with 3/8" opened end or socket wrench.

2.5.2 With two people slide the cabinet off from one side so two of the casters will touch the ground at the same time.

2.5.3 Once the first two casters are touching the ground carefully slide the remaining part of the pallet out from under the cabinet.

2.6 Footswitch Valve and Blast Hose Setup

2.6.1 Locate the footswitch valve (E) and blast hose (K) assembly in box at bottom of cabinet.

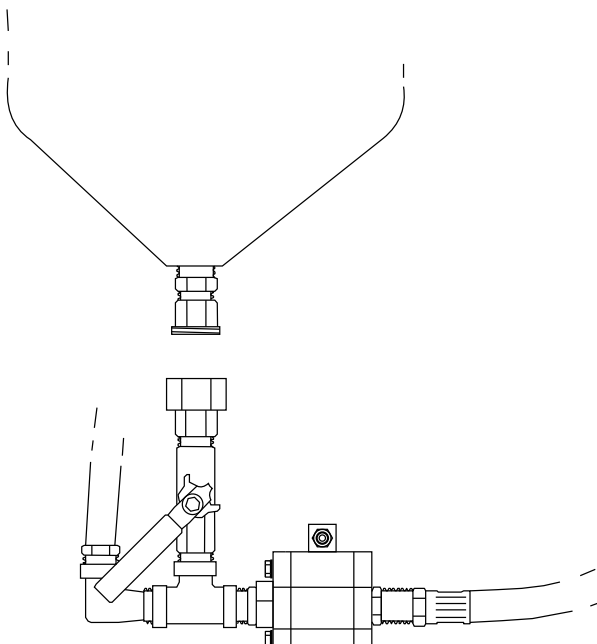

2.6.2 On some shipments it is required to attach pipe union nut (J) to fitting at the bottom of the pressure pot. Use wrench to tighten.

2.7 Foot Pedal Connection

2.7.1 The foot pedal (F) has a short hose and a long hose with quick disconnect fittings. Connect the short hose to quick disconnect fitting on footswitch valve (E). Connect the long hose to the quick disconnect fitting located between water separator (G) and the air inlet valve (C).

2.8 Dust Collector Connection

2.8.1 Connect the dust collector hose to the connection tube on the rear of the cabinet. Do not plug any other devices to rear of 1924.

2.8.2 Connect the dust collector to power plug to the socket at the top rear of the sandcarving system.

2.8.3 The top of the dust filter bag should overlap the canister and the dust motor top should fit in the lip of the canister.

2.9 Electrical Connection

2.9.1 Plug cabinet into a grounded 110-120 volt electrical outlet with 15-amp circuit breaker.

2.9.2 Turn on power-switch to test proper function of the light and dust collector.

2.10 Adding Abrasive Media

2.10.1 The system has been shipped without the abrasive media in the pot. Turn the dust collector on, place unopened 50lb bag of 150 grit aluminum oxide abrasive into the cabinet. Slit the top of the bag open. Close the side door and empty the bag using the front armhole access. After the dust has cleared remove the bag from the cabinet.

! NOTICE

The abrasive media will break down over time causing more dust in the cabinet and slower blasting. New abrasive should never be added to old abrasive. Instructions for removing worn abrasive and adding new abrasive are covered in the Operation Manual. DO NOT over fill the pot with more than 50 lbs of abrasive; this may prevent the pot closure cap from sealing.

2.11 Air Compressor Requirements

NOTE: Customer Supplied and used only for the Cabinet.

The following specs are a minimum requirement for an air compressor. If blasting at higher pressures a larger compressor is required.

1. Air Compressor
 - Below are the Minimum Requirements
 - 2.0 horsepower, High Performance Cast Iron Air Compressor
 - Free Air CFM @ 90 PSI: 5.5
 - Free Air CFM @ 135 PSI: 4.9
 - Tank Capacity (Gal): 20
 - Moisture Separator is recommended for high humid climate

- Air hose with 1/4" industrial quick coupler fittings.

2.12 Dedicated Air Compressor Set-up

! NOTICE

DO NOT connect air to the cabinet until you are instructed to do so in the operation manual. Follow all procedures found in compressor manufacturers literature.

2.12.1 In high humid climates install a moisture separator to the compressor. Moisture getting into the abrasive can cause the pressure pot to clog and prevent the flow of abrasive. If you are using a moisture separator, install it to the output connection on the compressor. This connection is generally after the air pressure regulator.

2.12.2 Connect air hose to moisture separator.

2.12.3 The end of the air hose should have a female quick disconnect coupling that will connect to the male fitting (N) on the pressure pot.

2.12.4 Turn on the compressor and let it fully charge with air but DO NOT connect the air hose to the pressure pot yet.

2.12.5 Air compressors generally have an output regulator and two air pressure gauges. One gauge is to indicate the pressure in the tank and the other is the output pressure the customer sets. Set the output pressure regulator to 90 psi.

2.13 Cabinet Operation

2.13.1 Locate the Operation Manual to continue.

OPERATION

! WARNING

DO NOT attempt to operate this equipment until you have read and understand the potential hazards associated with operating this equipment and are able to follow all safety and operating procedures found in this manual.

Potential hazardous situations are identified whenever you see the following alert:

3.0 Operating Instructions

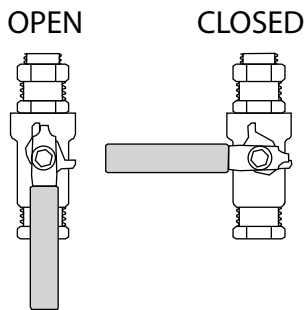

! NOTICE

The abrasive media will break down over time causing more dust in the cabinet and slower blasting. New abrasive should never be added to old abrasive. Instructions for removing worn abrasive and adding new abrasive are covered in the Operation Manual. DO NOT over fill the pot with more than 50 lbs of abrasive; this may prevent the pot closure cap from sealing.

3.1 Pressure Pot Settings:

3.1.1 Set Abrasive Flow Valve (D) at approximately half way open or approximately 45° angle.

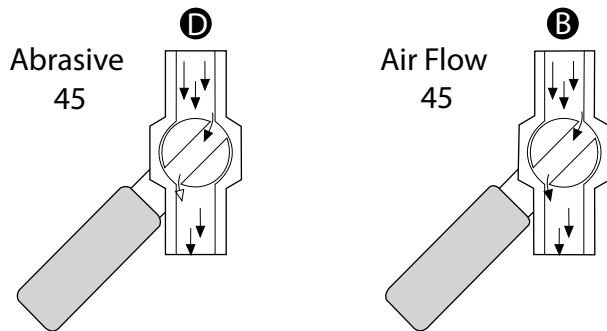

3.1.2 Set Abrasive Flow Valve (B) at approximately half way open or at 45° angle. Adjustments will need to be made as wear occurs to Blast Hose (K) and Blast Nozzle (T).

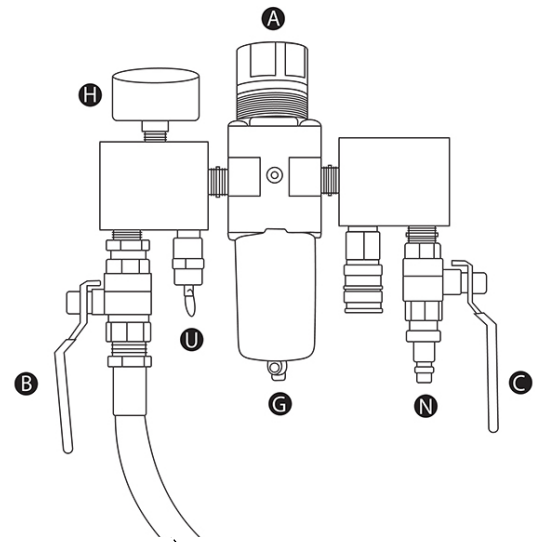

3.2 Connecting Air To Cabinet

3.2.1 Before connecting the air hose from the compressor to the pot, make sure the Air Inlet Valve (C) is in the "OFF" position (horizontal) and the air compressor has been set up according to instructions found in the Rayzist setup guide.

3.2.2 Connect the compressor air hose to the Air Inlet Valve Quick Disconnect Plug (N) but DO NOT turn the air inlet valve (C) to the on position yet.

! NOTICE

The pressure pot is equipped with a safety relief valve. If the pressure from the air regulator (A) rises above 100 psi the relief valve will pop open and release air. Since your incoming air is to be adjusted to 90 psi, this should never happen. This is a safety device and should never be used to drain air from the pressure pot. Draining air from the pot using this valve will cause abrasive to enter and damage the regulator.

! NOTICE

The air pressure regulator (A) sets the blasting pressure, which can be seen in gauge (H) only after the pressure pot has been pressurized. It is factory set at 30 psi.

3.3 Pressurizing the Pot

3.3.1 The pressure pot is located inside the cabinet below the metal grate. The pressure pot closure cap is attached to a linkage, which is movable from the pressure pot closure lever (L) on the left side of the cabinet. The purpose of the lever and linkage is to lift the pressure pot rubber seal located at the top of the pot. While holding the cap in the up position with lever (L) the air is turned on, this fills the pot, and presses the cap securely against the pressure pot rubber seal, sealing the pot and pressure inside. When the cap is in the down position there is a gap between the cap and the seal, which allows the abrasive from blasting to re-enter the pot.

3.3.2 Locate the Pressure Pot Closure Lever (L) and move it back and forth rapidly several times to shake off any abrasive that may be sitting on top of the closure cap.

3.3.3 Now push the lever away from you to lift the pressure pot closure cap against the rubber seal. While holding the lever firmly in this forward position, open the Air Inlet Valve (C). Count 3 seconds and then release the Pressure Pot Closure Lever (L). The pot should be closed and pressurizing at this point. The Air Pressure Regulator Gauge (H) should rise to the factory preset blasting pressure of 30 psi.

3.3.4 NOTE: If you hear air escaping inside the cabinet, turn off lever (C) and try again. If for some reason you cannot get the pressure pot closure cap to seal, call Rayzist and ask for technical help.

3.4 Adjusting Blasting Pressure

3.4.1 After pressurizing the pot the pressure regulator gauge (H) should read about 30 psi. If the gauge has a different reading make an adjustment as follows: Unlock the Air Pressure Regulator Knob (A) by pulling upwards. Twist clockwise to increase blast pressure or counter clockwise decrease blast pressure. Set regulator to desired pressure, and then press down to lock the knob.

3.5 Adjusting Abrasive and Air flow

3.5.1 Turn on the dust collector and lights. Check dust collector connection and

confirm the motor top is secure on the dust collector container and the cloth bag is secure in container.

! NOTICE

DO NOT connect air to the cabinet until you are instructed to do so in the operation manual. Follow all procedures found in compressor manufacturers literature.

3.5.2 Put on the rubber blasting gloves and hold the Blast Hose (K) and have the tip pointing downwards towards the grate about 6" to 8" away. Step on the foot pedal and watch the flow of abrasive as described above.

! NOTICE

Air Flow Valve (B) adjusts how much air pushes the abrasive through the Blast Hose (K). Less air flow = more abrasive. More air flow = less abrasive.

3.5.3 If necessary adjust Air Flow Valve (B) to achieve the proper balance of abrasive and air. If there is too much abrasive open valve more; if not enough close the valve slightly.

3.6 Sandcarving

3.6.1 Turn on cabinet power switch located above the left side of cabinet; the dust collector and lights should both begin operating.

3.6.2 Use rubber gloves before blasting. (rubber or latex safety gloves can be purchased from a local hardware store).

3.6.3 Place item to be etched inside cabinet. Hold Blast Hose (K) in hand (like a pencil).

3.6.4 By pressing on the Foot Pedal (F), the air/abrasive flow starts; by letting off the Pedal, the air/abrasive flow stops.

3.6.5 Depress Foot Pedal (F), holding Blast Hose (K) 3" - 4" away from item, use slow sweeping motions across image area to be etched.

! NOTICE

Always depressurize the pressure pot when you are done blasting for the day. It is not necessary to do this if you are intermittently blasting throughout the course of the day but should always be done when you are done blasting for an extended period. Instructions for depressurizing the pot are covered below.

3.7 Depressurizing the Pressure Pot and recycling the abrasive

! NOTICE

Always use the following procedure when you are finished blasting or you run out of abrasive.

! WARNING

NEVER attempt to open the pressure pot closure cap using the Pressure Pot Closure Lever (L). This could cause a sudden UNSAFE release of compressed air. The pressure pot opens automatically when the pot is depressurized.

3.7.1 After you are done blasting, or you run out of abrasive during blasting, keep the dust collector turned on and then turn off the Air Inlet Valve (C). Then depress the foot pedal until the pot is depressurized. When all the air pressure is exhausted the pot closure cap will automatically open

and the abrasive that has collected in the bottom of the cabinet will flow back into the pot. You can get additional abrasive to fall back into the pot by tapping on the outside of the cabinet just above the pot. The pot is now filled again and is ready for the next time you blast.

! NOTICE

If for some reason, the pot closure cap does not open the pot after the Air Pressure Regulator Gauge (H) has reached zero, you can open the closure manually by pulling the Pressure Pot Closure Lever (L) towards you. NOTE: for safety reasons this should never be done unless the Air Pressure Regulator Gauge (H) reads zero and the main air supply is disconnected.

! WARNING

Never leave the pot pressurized over night. If valve (C) is left on and the air compressor supply shuts off at night the pot will depressurize and automatically open. When the air compressor comes back on the next day, air will run through the opened pot and abrasive and dust will blow out through the arm holes of the cabinet creating a hazardous condition of dust in the air.

MAINTENANCE

! WARNING

DO NOT attempt to maintain this equipment until you have read and understand the potential hazards associated with operating this equipment and are able to follow all safety and operating procedures found in this manual.

Potential hazardous situations are identified whenever you see the following alert:

4.0 Maintenance

! WARNING

Never leave the pot pressurized over night. If valve (C) is left on and the air compressor supply shuts off at night the pot will depressurize and automatically open. When the air compressor comes back on the next day, air will run through the opened pot and abrasive and dust will blow out through the arm holes of the cabinet creating a hazardous condition of dust in the air.

4.1 Daily Maintenance

4.1.1 Check to see if excess water is building up in the water separator (G) if necessary drain the water, by pushing button at bottom of bowl. Drain water from air compressor to reduce moisture in the line.

4.2 Periodic Maintenance

4.2.1 Abrasive Sifting Screen Cleaning: Looking inside the cabinet through the grate to the bottom of the cabinet, and top of the pressure pot opening, you will see a wire screen material. This screen material is designed to prevent unwanted materials such as tape or stencil material from entering the pressure pot. Periodically the build up of these materials will need to be removed. This is best done at the beginning of use before the pressure pot is pressurized. Start by removing the steel grate from the inside of the cabinet. Next, find an item you can use to push any remaining

abrasive through the screen so that all that remains on top of the screen are unwanted materials. Use a shop vacuum with a long vacuum extension and vacuum the unwanted materials out of the cabinet. Replace the grate.

4.3 Abrasive Removal for Disposal

4.3.1 Abrasive life expectancy may be up to 40 hours. Worn abrasive does not cut as fast as new abrasive and will generate more dust during blasting.

! NOTICE

DO NOT add new abrasive to worn abrasive. Always replace worn abrasive with new abrasive using the following procedures. Always wear respiratory protection for this procedure.

4.3.2 Remove the Blast Nozzle (T) from the Blast Hose (K). Place the disposal bucket or disposal trash liner in the cabinet and close the door. Turn on the dust collector. Place the blast hose into the bucket or trash liner. Set the Air Pressure Regulator Gauge (H) to 20 PSI by adjusting Air Pressure Regulator. Knob (A). Turn off the Air Flow Valve (B). Press the Foot Pedal (F) until the bucket is full or the pressure pot is empty. Put worn abrasive in plastic bag and dispose of according to local regulations. Repeat as necessary until abrasive is completely emptied.

13



4.4 Adding New Abrasive

4.4.1 With the dust collector on, place unopened 50lb bag of abrasive into the cabinet. Slit the side of the bag open allowing the abrasive to flow into the bottom of the cabinet. Close the side door and empty the remainder of the bag using the front armhole access. After the dust has cleared remove the bag from the cabinet.

4.5 Viewing Glass Replacement

! WARNING

Edges of glass can be sharp and cut through your skin. Wear protective gloves when handling the glass.

4.5.1 The window consists of two 14" x 20" panes of glass, the outer double safety laminate (replacement not required), and the inner 1/8" thick single strength glass. The inner single strength glass will get frosted over time and will impair visibility.

! NOTICE

14" x 20" x 1/8" thick single strength window glass can be purchased from a local glass retailer.

4.5.2 To replace: loosen (but do not remove) the five window bracket screws on the bottom of the window and the four

bracket screws on the top of the window. Carefully slide both panes of glass out to the right or left of the cabinet.

4.5.3 Replace the single strength glass pane and slide both back into the window brackets. Tighten five bottom bracket screws so that the bracket is firmly against the face of the cabinet. Tighten 4 bracket screws on top until glass is slightly compressing the foam seal under the glass. DO NOT over tighten these 4 screws.

4.6 Replacing Tube Sleeve

! WARNING

Disconnect air and depressurize pot before replacing the tube sleeve.

4.6.1 The sleeve will fail when a small hole is worn through the sleeve. Evidence of this is that the foot switch will no longer turn off the flow of abrasive and air.

4.6.2 To replace sleeve, Disconnect air and DEPRESSURIZE the pressure pot according to the instructions in operation manual.

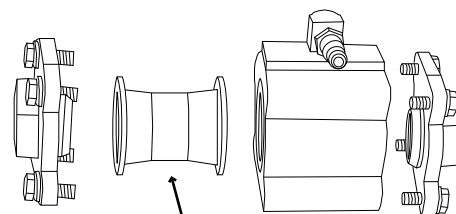
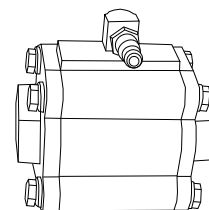

FSV Sleeve

4.6.3 Remove the eight bolts to disassemble both sides of the Foot Switch Valve Assembly (E).

4.6.4 Replace the sleeve and re-install bolts. After hand tightening the bolts, tighten them with a wrench to properly seal the gasket.

4.7 Replacing the Blast Nozzle (T)

4.7.1 Replace when the Blast Nozzle (T) orifice exceeds 1/8". A large orifice may cause damage to the mask, and require a higher rate of CFM demand from the air compressor.

4.8 Long Term Maintenance

4.8.1 Several items may need replacement after significant machine operation. The following is a list (instructions for these are supplied with the replacement parts).

4.8.2 Blast Hose (K)

4.8.3 Weather Strip Seal

4.8.4 Light bulb replacement – Always Turn off unplug power from the unit. Do not exceed 100 watt bulbs.

4.8.5 Dust collector dust bag– The dust collector bag is made of a breathable material and should operate for six months to one year when daily and periodic maintenance is followed. Periodically remove cloth bag and empty dust collected at bottom of container. Shake bag manually to free any dust embedded in lining of bag. Protective goggles and mask must be worn when performing maintenance to dust collector. Over time the dust collector bag may need to be replaced if dust in the cabinet becomes excessive and is obstructing visibility.

4.8.6 Dust collector filter– The dust filter is located under the motor of the dust collector. Periodical maintenance is required to maintain the operation of the dust filter. Remove lid of dust collector and this will expose the filter, use an air gun to remove any dust or debris on filter. The dust requires replacement after one year or when excessive dust is viewed in blasting cabinet.

Parts available at www.rayzist.com/store

Keep spare parts on-hand

Part	Part #
Heavy Duty Blasting Hose (K)	HDHBLK
Carbide Nozzle (T) – 3/32"	NZ32
Aluminum Oxide Abrasive 150 Grit	AO150
Std Foot Pedal w/ hoses	FPRS
Foot Switch Valve Repair Kit	FSVKIT

Dust Collector Replacement Parts

Part	Part #
Dust Vacuum Bag	1924DB
Filter	1924Filter
Vacuum MotorTop	VMotor

SWITCH WIRING DIAGRAM

